

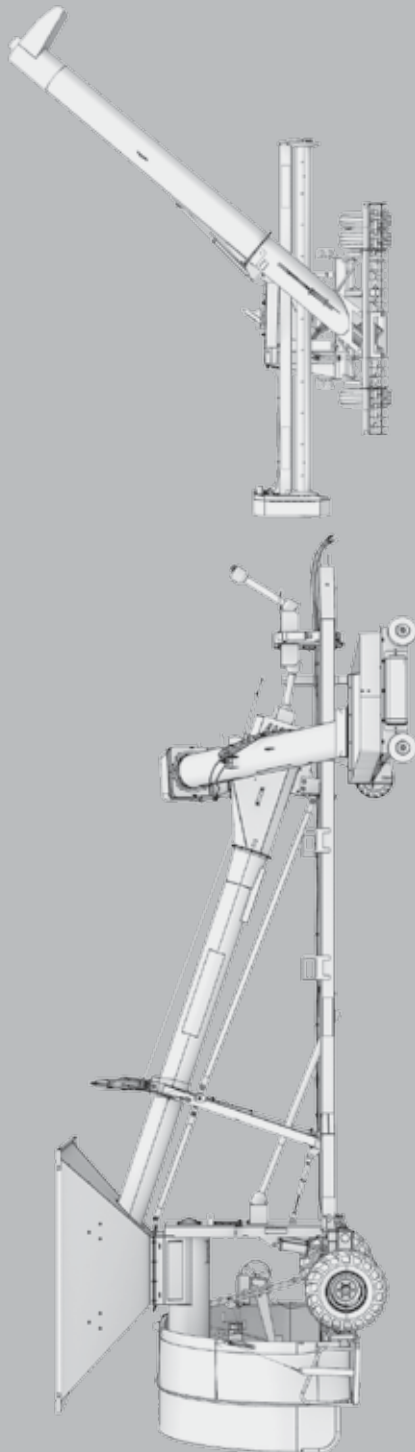

LOFTNESS

GL SYSTEM 10™

GRAIN BAG UNLOADER
GRAIN BAG LOADER
TRUCK UNLOADING AUGER



LOFTNESS™

GRAIN LOGIX™

GRAIN BAG STORAGE SYSTEMS
WWW.GRAINLOGIX.COM

Specifications, Performance and Features Reference Guide



LOFTNESS

GL SYSTEM10™

GRAIN BAG LOADER

Product Specifications

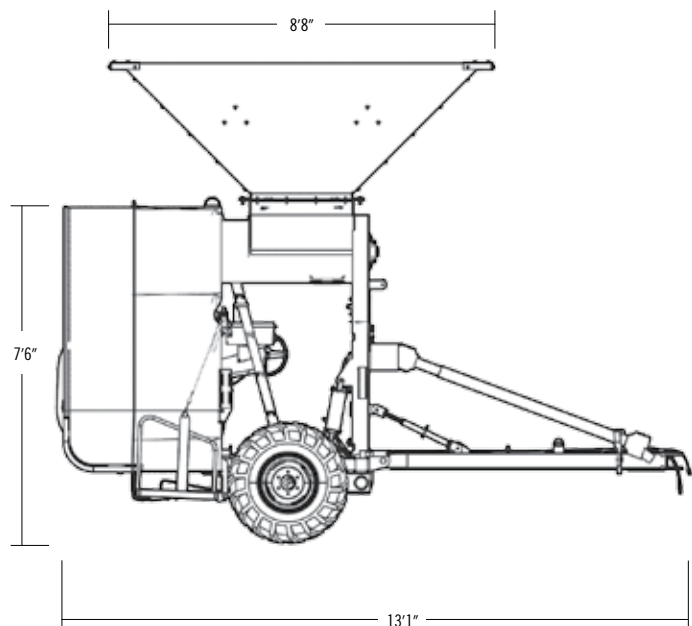
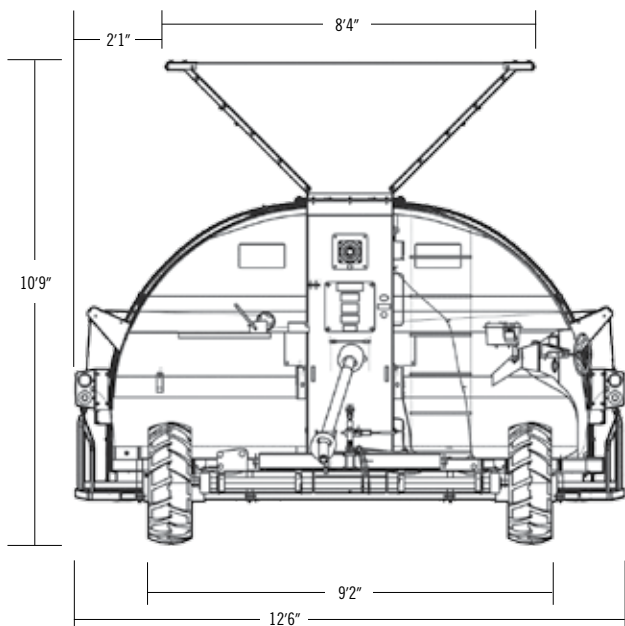

BAG LOADER MODEL NUMBER

GBL10

UNIT WEIGHT

4080 LBS

TRACTOR REQUIREMENT
Without Truck Auger

50 HP - 540 PTO

TRACTOR HYDRAULIC
Without Truck Auger

6 GPM

OPTIONS

ROLL TARP

Supplied by ACI
agricover.com - 866-414-5422

TRUCK UNLOADING AUGER

with swing hopper (Transport Kit) – PN-N27921

Product Specifications

- Shown Mated to System10 Bag Loader
- Fits LOFTNESS Grain Bag Loaders
- Current and Past Production GBL-10s SN 52-147 & higher

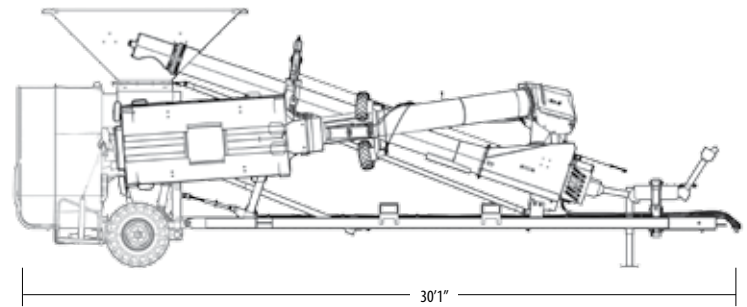
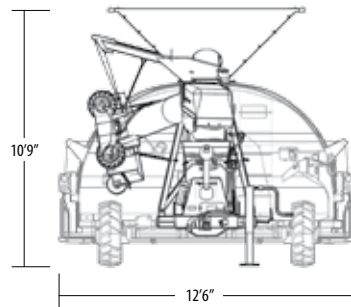
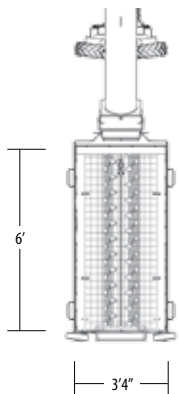
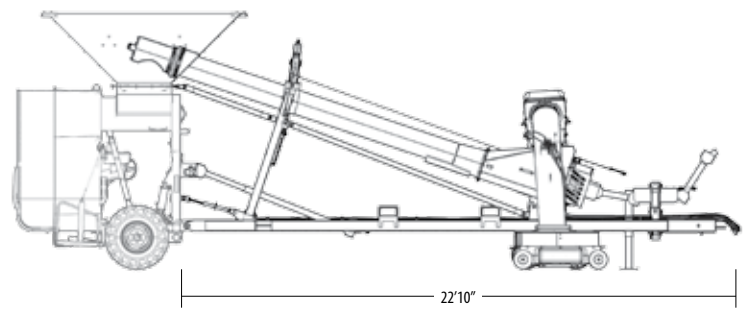
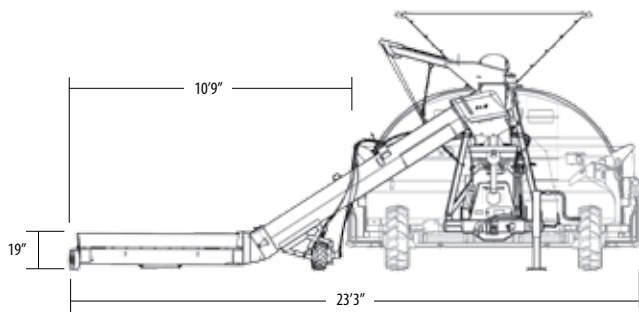

TRUCK UNLOADING AUGER NUMBER	PN N27921
UNIT WEIGHT	4540 LBS, 8620 LBS COMBINED
TRACTOR REQUIREMENT With Bag Loader	1000 RPM PTO 120 HP
TRACTOR HYDRAULIC With Bag Loader	6 GPM
OPTIONS	1-3/8 – 1000 PTO – N29020 1-3/4 – 1000 PTO – N29021

LOFTNESS

GL SYSTEM 10™

GRAIN BAG LOADER

Product Specifications

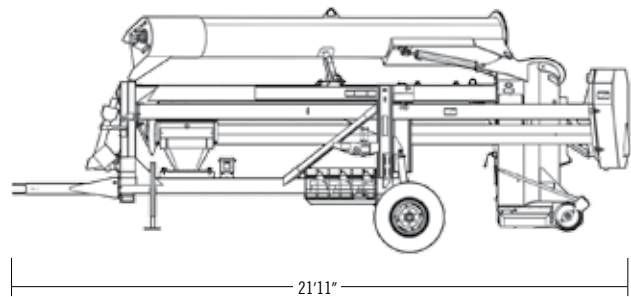
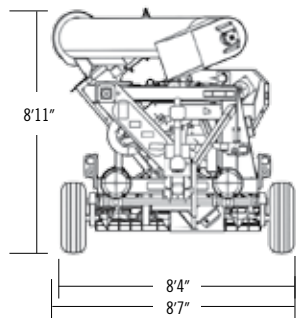
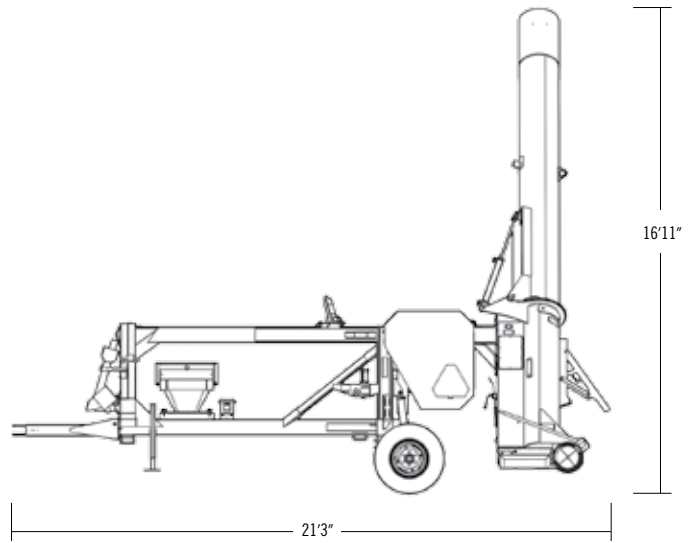
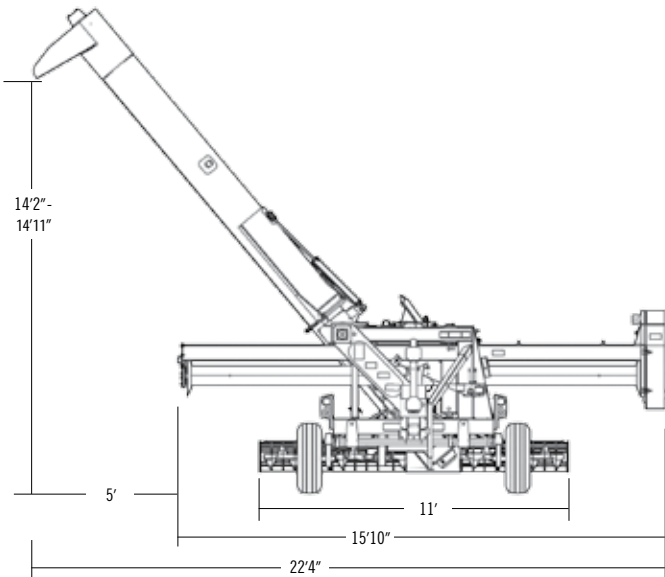

GL SYSTEM 10 GBU MODEL NUMBER	GBU10
UNIT WEIGHT	5760 LBS
TRACTOR REQUIREMENT	50 HP - 540 PTO
TRACTOR HYDRAULIC	6 GPM
OPTIONS	9 FOOT BAG CROSS AUGER KIT - N22771 DUAL WHEEL SOFT TERRAIN KIT - N22753 OPTIONAL HIGH CAPACITY AUGER - N25170

Performance & Feature Reference



Model Number	GBL 10	N27921 (Truck Unloading Auger)	GBU 10
Operating Weight	4080 pounds	4540 pounds	5760 pounds
Operating Dimensions			
Length	170 in.	362 in. / w GBL	255 in.
Width	150 in.	290 in.	269 in.
Height	129 in.	129 in.	209 in.
Storage/Travel Dimensions			
Length	170 in.	362 in. / w GBL	263 in.
Width	150 in.	150 in.	103 in.
Height	130 in.	130 in.	107 in.
Width	(136 in with travel kit)		
Hopper Dimensions			
GL-10 Loader	100 in. X 104 in.		
GL-10 Truck Auger		40 in. X 72 in. X 12 in.	
GL-10 Truck Auger w/extension		40 in. X 72 in. X 19 in.	
PTO			
RPM	540	1000	540
Horsepower	50	120	50
Shaft Size / Type	6-B Spline	1 3/8 or 1 3/4	6-B Spline
PTO Driveline Type	Walterscheid W2400	Walterscheid W2400	Walterscheid W2400
Hydraulics			
GPM (required)	6	6	6
PSI (required)	2,000	2,000	2,000
Connector Type	Quick Couplers	Quick Couplers	Quick Couplers
Auger Sizes			
Primary Auger	17 in. / 385 RPM	13 in. / 540 RPM	
Discharge Auger			17 in. /331 RPM
Cross Auger			10 in. /356 RPM
Secondary Auger		14 in. / 540 RPM	Optional 5 in. Auxiliary
Twin Hopper Auger		7 In. /750RPM	
Wheels / Tires			
Wheel Size	33 in.	15 in.	31 in.
Tire Size	12.5L-15	16-6.5	11L-15
Tire Type	SureGrip Traction	Foam Filled Traction Tire	Implement
Operational Braking System	Hydraulic Disc		
Performance			
Transfer Capacity	26,000 Bushels / Hr.	11,900 Bushels / Hr.	8,500 Bushels / Hr.
Bag Handling Capacity			
Diameter	10 Foot Bags		9 foot or 10 Foot Bags
Max. Length	300 Feet		300 Feet



LOFTNESS

SPECIALIZED EQUIPMENT. UNLIMITED INNOVATION.

Committed to our customers' success and the power of innovation.

The power of innovation comes from truly understanding a customer's challenges and goals. Whatever the challenge, Loftness is dedicated to ensuring customer success by delivering focused design and engineering excellence with unmatched quality and craftsmanship.

Loftness Equipment— Delivering value by seeing challenges as opportunities.

When searching for equipment that is productive and reliable, built with exceptional quality, and engineered to have long-lasting reliability, Land, Vegetation, and Agricultural Management professionals look to Loftness as the innovation leader in the specialized equipment industry.

Loftness GrainLogix and the GL System 10 line of grain bagging equipment is the newest example of innovation from Loftness Specialized Products.

Because Loftness understands the critical nature of grain bag storage strategies, agriculture professionals will immediately see value in supporting their grain bagging operations with GrainLogix and the Loftness GL System 10 line of products.

LOFTNESS

GRAINLOGIX™

GRAIN BAG STORAGE SYSTEMS

WWW.GRAINLOGIX.COM



LOFTNESS GrainLogix Equipment. Grain Bag Storage success starts here.

At Loftness we believe that your successful grain bagging operation is a direct reflection on our commitment to designing, building and delivering the finest and most innovative grain storage bagging systems available.

Grain Bag Storage Success starts with Loftness and GrainLogix, because we understand that the most important part of any grain bag storage strategy is the reliability of your equipment and the company that stands behind it.



LOFTNESS 
SPECIALIZED EQUIPMENT. UNLIMITED INNOVATION.

WWW.LOFTNESS.COM



LOFTNESS

SPECIALIZED EQUIPMENT. UNLIMITED INNOVATION.

LOFTNESS

GRAINLOGIX™

GRAIN BAG STORAGE SYSTEMS

WWW.GRAINLOGIX.COM

LOFTNESS

GL SYSTEM10™
GRAIN BAG UNLOADER
GRAIN BAG LOADER
TRUCK AUGER



LOFTNESS

GL SYSTEM12™
HD GRAIN BAG UNLOADER
HD GRAIN BAG LOADER
HD TRUCK AUGER



LOFTNESS

GL SYSTEM12™
HD GRAIN BAG LOADER

Call us or ask your local Loftness Dealer about the new Loftness GrainLogix System 12 High Performance 12 foot Grain Bag Loader.

LOFTNESS

Loftness Specialized Equipment
P.O. Box 337
Hector, Minnesota 55342 USA

Toll Free US & Canada: 800-828-7624
International 320-848-6266
email: info@loftness.com
www.loftness.com
www.grainlogix.com

Walterscheid and SureGrip are trademarks of their respective companies.
GrainLogix, GL System10, GL System12 are trademarks of Loftness Corporation.

L10031 - GL Sys 10